

# ST701D

## Microwave Sensor



## Instruction

### Welcome to use ST701D Microwave Sensor!

The product is a new saving-energy switch; it adopts microwave sensor mould with high-frequency electro-magnetic wave (5.8GHz), integrated circuit. It gathers automatism, convenience, safety, saving-energy and practicality functions. The wide detection field is consisting of detectors. It works by receiving human motion. When one enters the detection field, it can start the load at once and identify automatically day and night. Its installation is very convenient and its using is very wide. Detection is possible through doors, panes of glass or thin walls.

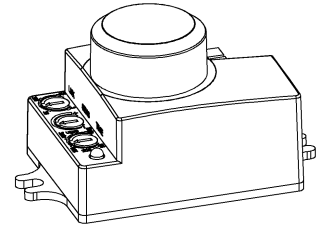

### SPECIFICATION:



Power Sourcing: 220-240V/AC

Power Frequency: 50/60Hz

Ambient Light: <3-2000LUX (adjustable)

Time Delay: Min.10sec±3sec

Max. 12min±1min

Rated Load: 1200W   
300W 

Detection Range: 360°

Detection Distance: 1-8m (radius) adjustable

HF System: 5.8GHz CW radar, ISM band

Transmission Power: <0.2mW

Installing Height: 2-6m

Power Consumption: approx 0.9W

Detection Motion Speed: 0.6-1.5m/s

### FUNCTION:

- Can identify day and night: It can work in the daytime and at night when it is adjusted on the "sun" position (max). It can work in the ambient light less than 3LUX when it is adjusted on the "3" position (min). As for the adjustment pattern, please refer to the testing pattern.
- SENS adjustable: It can be adjusted according to using location. The detection distance of low sensitivity could be only 2m and high sensitivity could be 16m which fits for large room.
- Time-Delay is added continually: When it receives the second induction signals within the first induction, it will restart to time from the moment.
- Time-Delay is adjustable. It can be set according to the consumer's desire. The minimum time is 10sec±3sec. The maximum is 12min±1min.

**NOTE:** the high-frequency output of the HF sensor is <0.2Mw- that is just one 5000<sup>th</sup> of the transmission power of a mobile phone or the output of a microwave oven, the baby can't touch it

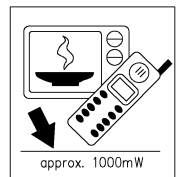
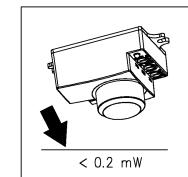

**INSTALLATION:** (see the diagram)

- Switch off the power.
- Fix the bottom on the selected position with the inflated screw through the screw holes at the side of the sensor.
- Connecting the power and the load to sensor as per the connection-wire sketch diagram.
- Switch on the power and test it.

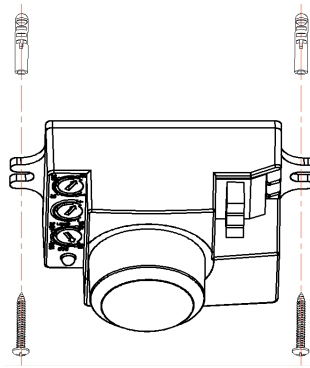

**CONNECTION-WIRE DIAGRAM:**

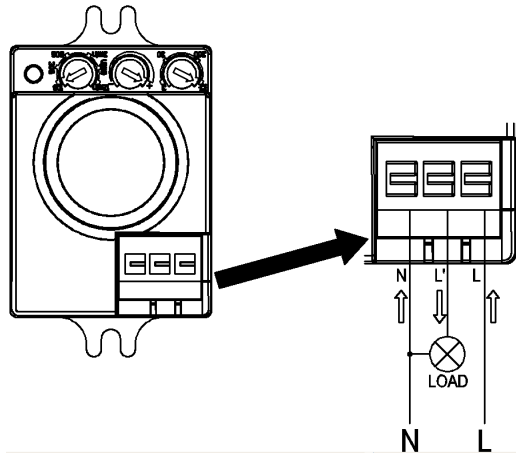

**TEST:**

- Turn the LUX knob clockwise on the maximum (sun). Turn the SENS knob clockwise on the maximum (+). Turn the TIME knob anti-clockwise on the minimum (10s).  
And 10sec±3sec later the light will be off automatically. Then if the sensor receives induction signal again, it can work normally.
- When the sensor receives the second induction signals within the first induction, it will restart to time from the moment.
- Turn LUX knob anti-clockwise on the minimum (3). If the ambient light is less than 3LUX (darkness), the inductor load could work when it receives induction signal.

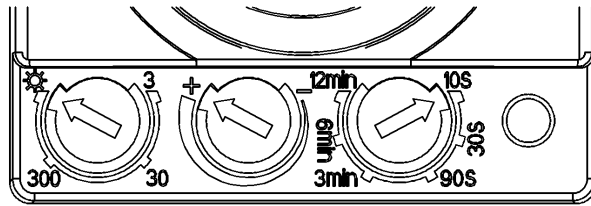

**LUX SENS TIME**

**Note:** when testing in daylight, please turn LUX knob ☀ (SUN) position, otherwise the sensor lamp could not work!

**NOTES:**

- Electrician or experienced human can install it.
- Can not be installed on the uneven and shaky surface
- In front of the sensor there shouldn't be obstructive object affecting detection.
- Avoid installing it near the metal and glass which may affect the sensor.
- For your safety, please don't open the case if you find hitch after installation.
- In order to avoid the unexpected damage of product, please add a safe device of current 6A when installing microwave sensor, for example, fuse, safe tube etc.

**SOME PROBLEM AND SOLVED WAY:**

- The load don't work:
  - a. Check the power and the load.
  - b. Whether the indicator light is turned on after sensing? If yes, please check load.
  - c. If the indicator light is not on after sensing, please check if the working light corresponds to the ambient light.
  - d. Please check if the working voltage corresponds to the power source.
- The sensitivity is poor:
  - a. Please check if in front of the sensor there shouldn't be obstructive object that affect to receive the signals.
  - b. Please check if the signal source is in the detection fields.
  - c. Please check the installation height.
- The sensor can't shut automatically the load:
  - a. If there are continual signals in the detection fields.
  - b. If the time delay is set to the longest.
  - c. If the power corresponds to the instruction.