



48W WATERPROOF LED POWER SUPPLY SINGLE OUTPUT

SIZE:
L:307mm
W:20mm
H:20mm



■Features

- AC input: 100-240V
- Protection: short-circuit, overload, over voltage, over temperature
- 100% full-load aging test
- 300VAC surge for 5 seconds withstandable
- Working temperature up to 60°C
- 5G vibration tested
- High efficiency, long life span, and high reliability, low cost
- IP67 grade
- 2 years warranty

■Application

- *Industrial automation machinery
- *industrial control system
- *LED lighting
- *Mechanical and electrical equipment
- *Electronic instruments, equipments or apparatus



Specifications

Product No.		WPS-48-12	WPS-48-24
Output	DC voltage	12V	24V
	Rated Current	4A	2A
	Current Range	0-3.75A	0-1.88A
	Rated Power	48W	48W
	Ripple and	220mVp-p	250mVp-p
	Voltage adjustment	12±0.5V	24±0.5V
	Voltage Accuracy Note3	±3%	±3%
	Linear Adjustment Note4	±0.5%	±0.5%
	Load Adjustment Note5	±2%	1.50%
	Start and rise time	1000ms,30ms/230VAC 1000ms,30ms/110V	
Hold time (Typ)	50ms/230VAC 10ms/115AC		
Input	Voltage range	176-264VAC	
	Frequency range	47-63HZ	
	Efficiency (Typ)	82%	84%
	AC current (Typ)	0.48A/110V 0.35A/220V	
	Surge current (Typ)	Cold Start: 65A/230VAC	
	Current leak	<2mA/240VAC	
Protection	Overload	Larger than 105% of capacity restoration after abnormality removed	
	Overheat	Overheat protection starts when temperature in transistor over 140°C	
		Automatic restoration when temperature is back normal	
Environment	Working temp.	-20~+60°C(Refer to the tenuation curve)	
	Working humidity	20~90% RH, without condense	
	Storage temp & hmdty	-40~+80°C	
	Temp. coefficient	±0.03%/°C (0~50°C)	
	Vibration proof	10~500HZ,5G 10min / cycle, X、Y、Z axes 60 min each	
Safety reg. & EMC (Note.6)	Safety regulation	GB195110.1-2004/IEC61347-1:2003 CE(EMC+LVD)	
	Voltage proof	I/P-O:1.5KVAC I/P-FG:1.5KVAC O/P-FG:0.5KVAC	
	insulation resistance	I/P-O/P, I/P-FG,O/P-FG:100M Ohms/500VDC/25°C/70% RH	
	EMC irradiation	EN 55032:2015+A11:2020;EN IEC61000-3-2:2019	
	EMC disturbance proof	EN61000-3-3:2013+A1:2019	
Dimensions	Dimensions	307*20*20	
	Packing	0.4Kg	
Notes:	1. Unless specially indicated, all data are taken under 230VAC input, rated load and 25°C environment temp. 2. Ripple and noise: measured with a 12" double ripple cord connected in parallel with a 0.1µF and a 47 µF capacitor 3. Accuracy: including preset errors, linear adjustment rate and load adjustment rate. 4. Linear adjustment: taken under rated load from low voltage to high voltage. 5. Load adjustment: taken under 0~100% of rated load. 6. Power supply is taken as part of the whole system, and needs to be confirmed with terminal instruments for EMC.		

■Appearance

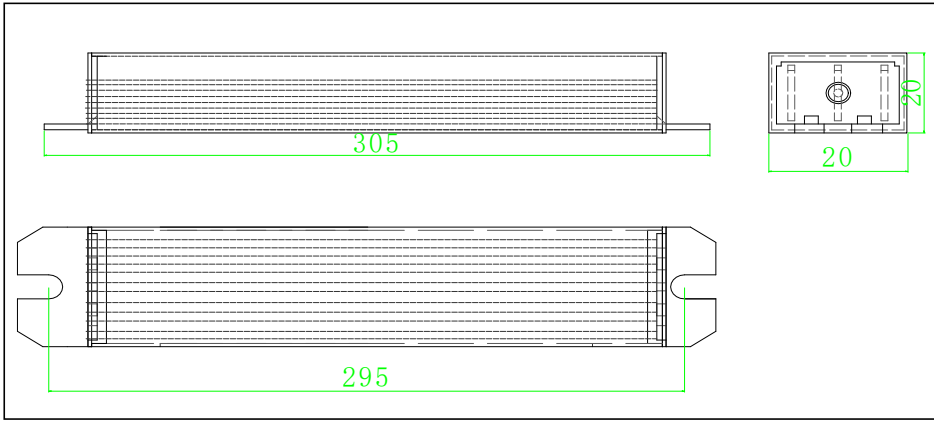

■Frame diagram

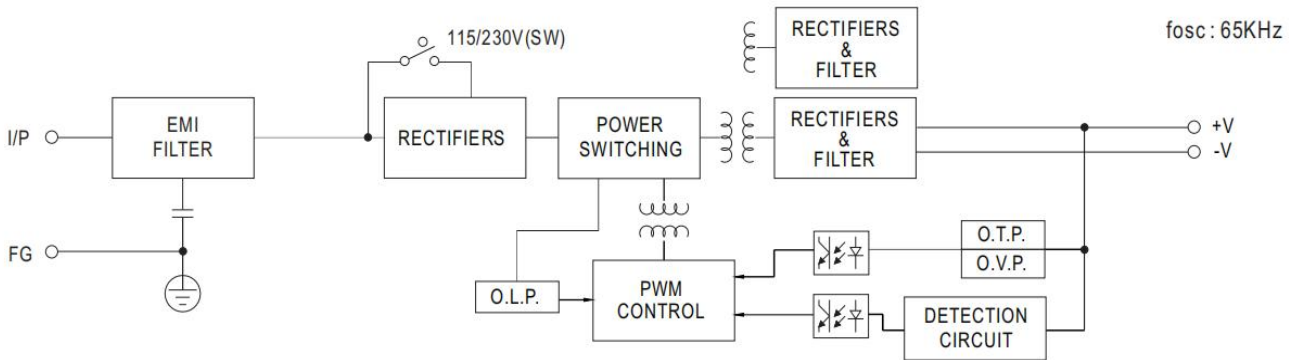

■Tenuation curve

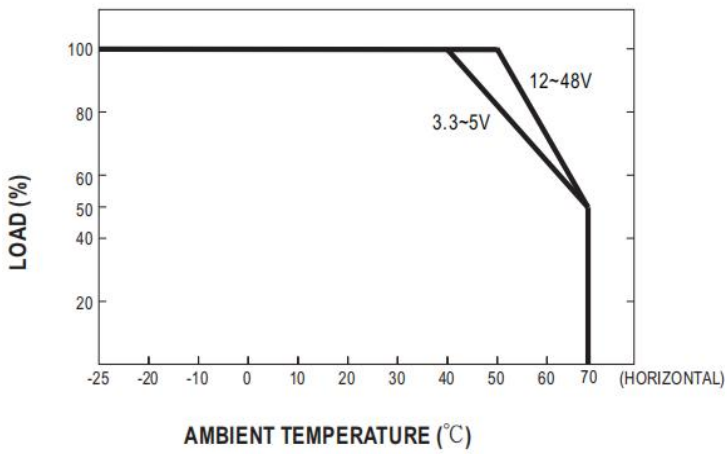

■Static property curve

